 = 1 sq foot

General Setup Instructions

- Read entire setup instruction manual prior to unpacking parts and pieces.
- The setup instructions are created specifically for this configuration.
- Setup instructions are laid out sequentially in steps, including exploded views with detailed explanation for assembly.

Cleaning & Packing

- For Cleaning Metal, Plex, & Laminate Parts: Use a **MILD NON-ABRASIVE** cleanser and soft cloth/paper towel to clean all surfaces.
- Keep exhibit components away from heat and prolonged sun exposure. **Heat and UV exposure will warp and fade components.**
- Retain all provided Packing Materials. All provided packing materials are for ease of repacking & component protection.

Disassembly

- For loss prevention, tighten all set screws and locks during disassembly.

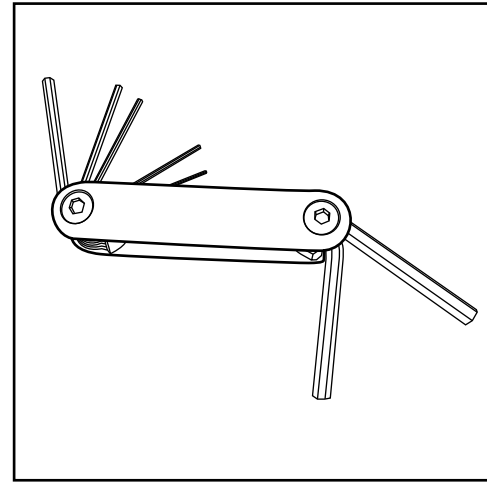

Hex Tool - Essential for Assembly

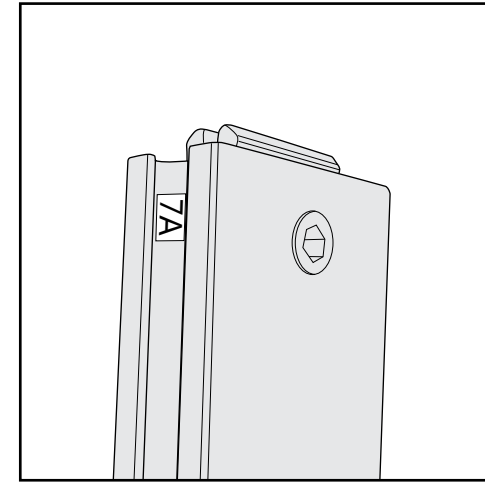

Part Identification - Numbering

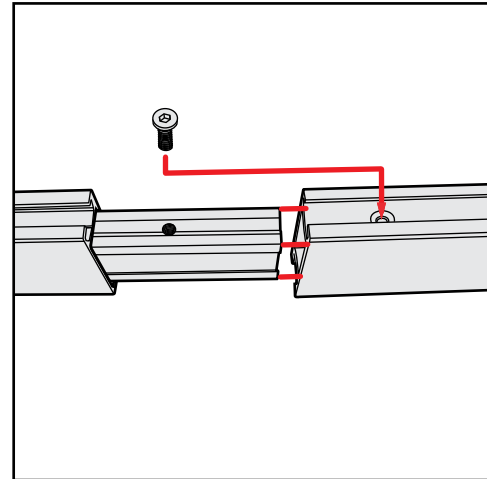

Spline Connection

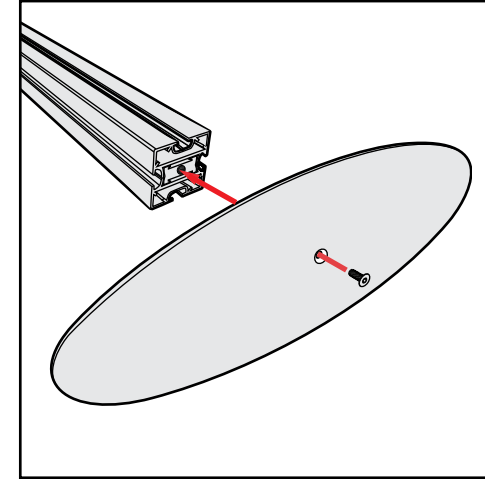

Base Plate & Extrusion Connection

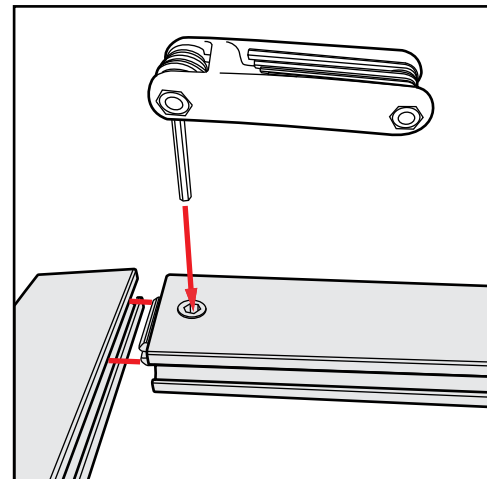

Extrusion & Lock Connection

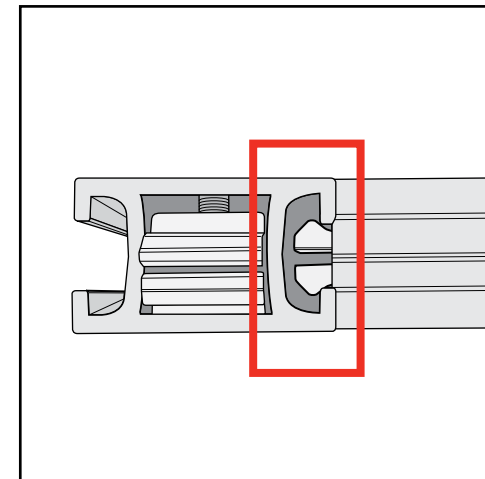

Engaged Lock



WARNING



DO NOT USE POWER TOOLS

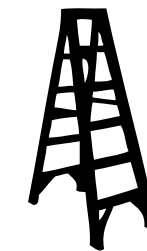

LADDERS OR LIFTS
MAY BE REQUIRED



ALL CONNECTIONS MUST
BE TIGHTLY SECURED

Straight Connection

When assembling frame, first attach all **straight connectors**, then attach **corner connectors**.

- 1) Place extrusions end-to-end.
- 2) Loosen all knobs, then slide **straight connectors** across the seam of extrusions.
- 3) Tighten all knobs to secure connection.

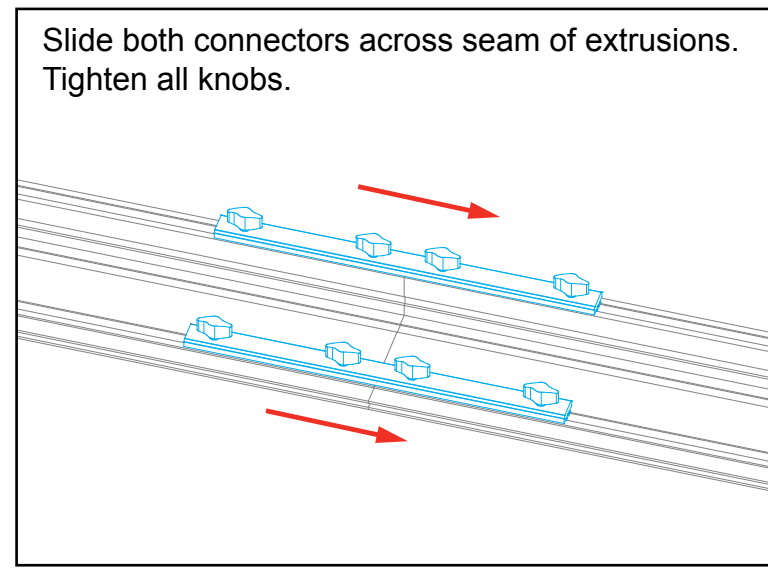
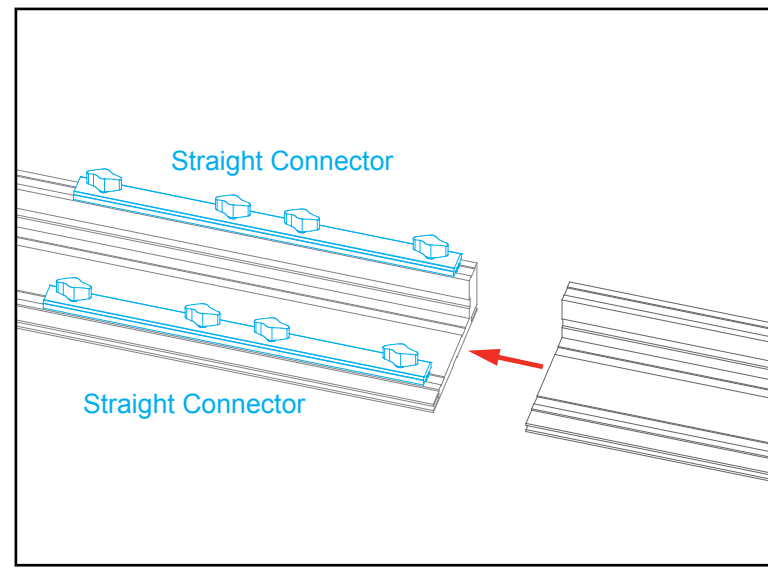

All knobs must be tightened securely to ensure a proper connection.

Disassembly

- 1) Loosen all knobs.
- 2) Slide connectors off of one extrusion.
- 3) Tighten knobs to prevent loss during packing & shipping.

Keep straight connectors in groove of extrusion. Do not remove connectors during disassembly.

Corner Connection

- 1) Loosen knobs, then slide vertical extrusions onto **corner connectors** of **lower** horizontal extrusion.
- 2) Slide **corner connectors** of **upper** horizontal extrusion into grooves of vertical extrusions.
- 3) Tighten all knobs to secure connection.

Disassembly

- 1) Loosen knobs on vertical extrusions.
- 2) Slide the vertical extrusions off of **corner connectors** on lower and upper horizontal extrusions.

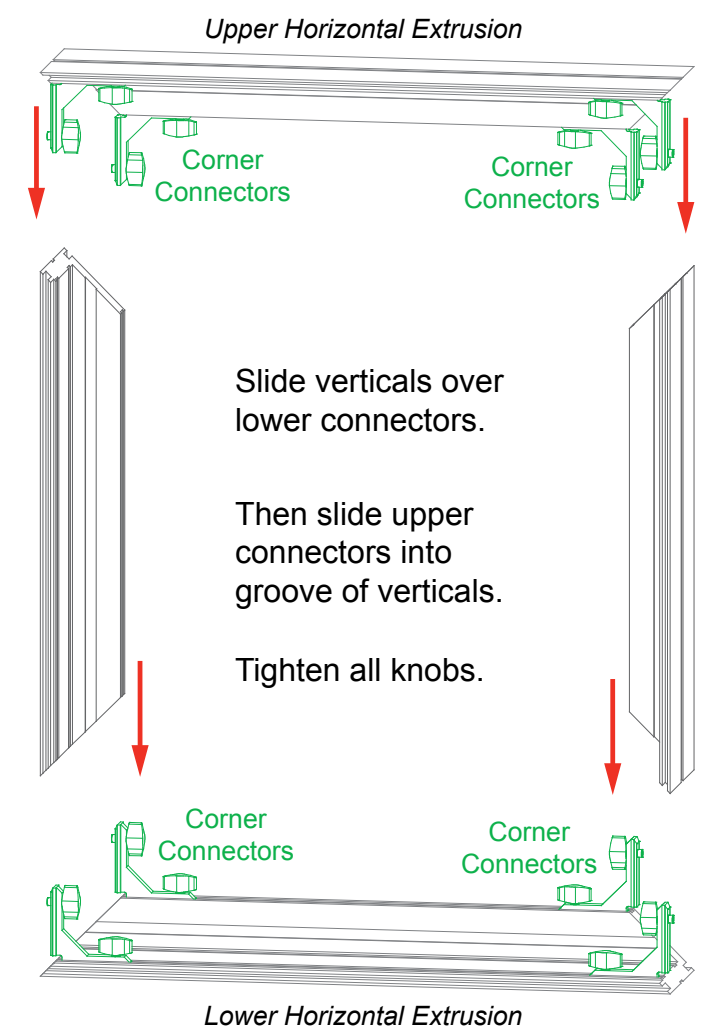

Adjust connectors if necessary to prevent gaps in connection.

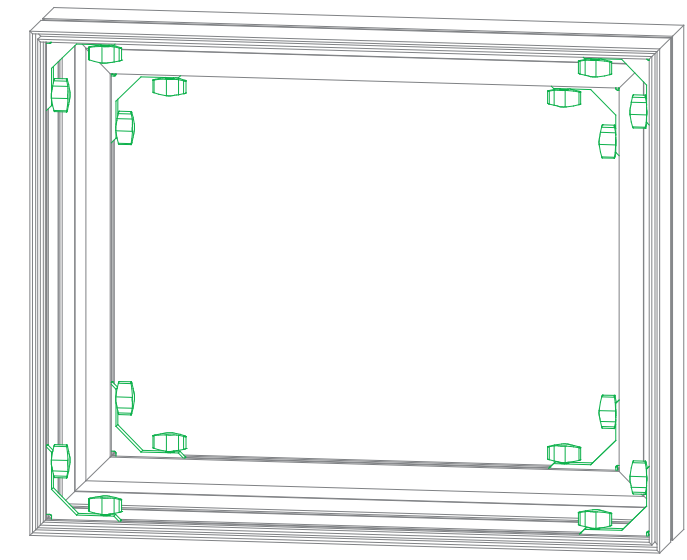

COMPLETED ASSEMBLY

All knobs must be tightened securely to ensure a proper connection.

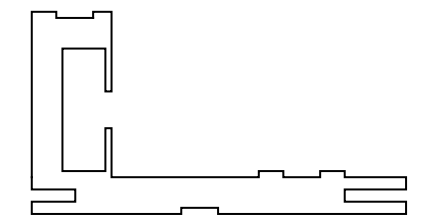

CEI110 Profile

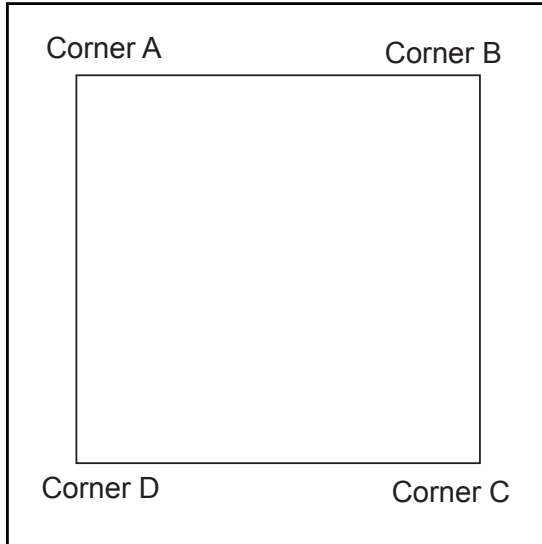

It is important to first insert graphic into each alternate corner then to the sides of the frame. If this is not done, graphic will not fit into the frame correctly.

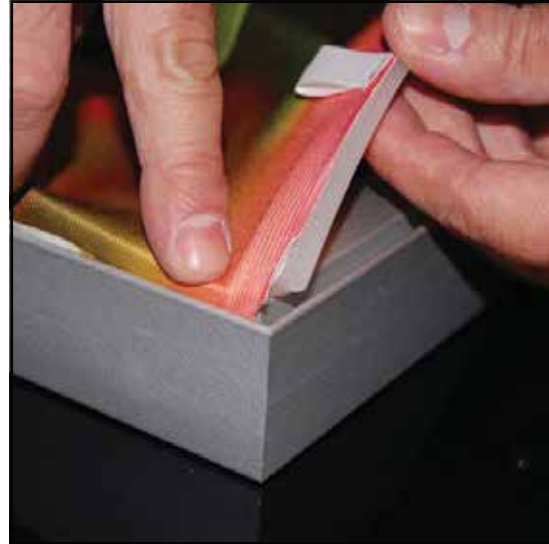

Step 1
Insert corner A. Turn edge of graphic so silicon welt is perpendicular to face of graphic. Insert narrow side of welt with fabric to outside into the channel. Repeat for other side of this corner.



Step 2
Repeat Step 1 for opposite corner C, then insert corner B, followed by corner D, to complete the installation of the corners.



Step 3
Once all corners are inserted, press one silicon edge into channel from corners and work toward the center. Make sure welt is fully inserted into channel. Continue until all sides are done. Smooth out edges of graphic.

Graphic Removal

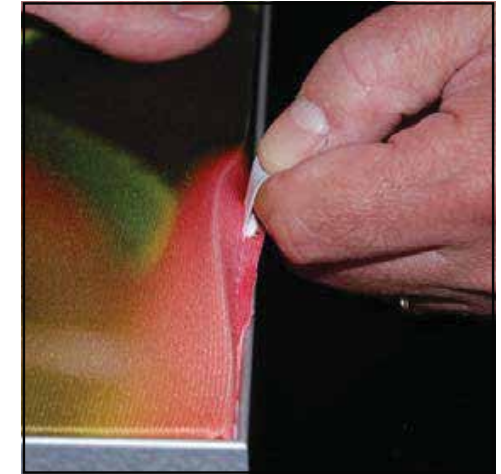

To remove the graphic from the frame, locate the fabric pull tab. Gently pull up on the tab to remove the fabric.

CRATE PACKING

Item	Qty.	Description
1	1	87" h CEI110 Vertical Extrusion
2	1	87" h CEI110 Vertical Extrusion
3	1	28" w CEI110 Horizontal Extrusion
4	1	74" w CEI110 Horizontal Extrusion
5	1	28" w CEI110 Horizontal Extrusion
6	1	28" w CEI110 Horizontal Extrusion
7	1	74" w CEI110 Horizontal Extrusion
8	1	28" w CEI110 Horizontal Extrusion
9	1	83.353" h Z45 Vertical Extrusion
10	1	86.252" h GS300 Vertical Extrusion
11	1	32" GS300 angled Extrusion
12	1	32" GS300 angled Extrusion
13	3	6" x 22" Base Plate

- Steps:
- Refer to the CEI-110 Frame Assembly general information page.*
- 1) Assemble horizontals [3-4-5] & [6-7-8] together.
 - 2) Connect verticals [1,2] between horizontal assemblies [3/4/5] & [6/7/8].
 - 3) Attach vertical [9] between horizontal assemblies [3/4/5] & [6/7/8]. See **Z45 Attachment** detail.
 - 4) Connect vertical [10] between horizontal assemblies [3/4/5] & [6/7/8]. See **GS300 Attachment** detail.
 - 5) Attach horizontals [11] & [12] to extrusions [2,5,8] as shown.
 - 6) Install Base Plates [13] to bottom horizontals, using bolts & wing nuts.

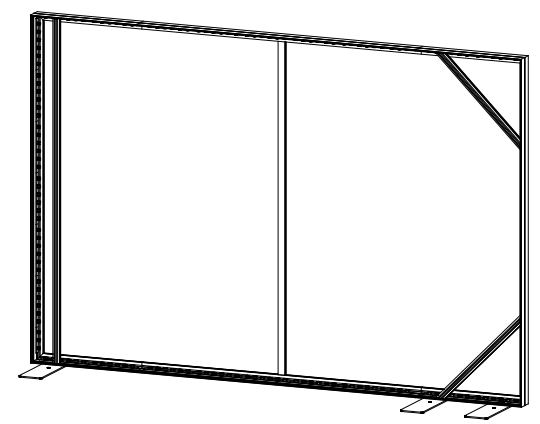

When assembled

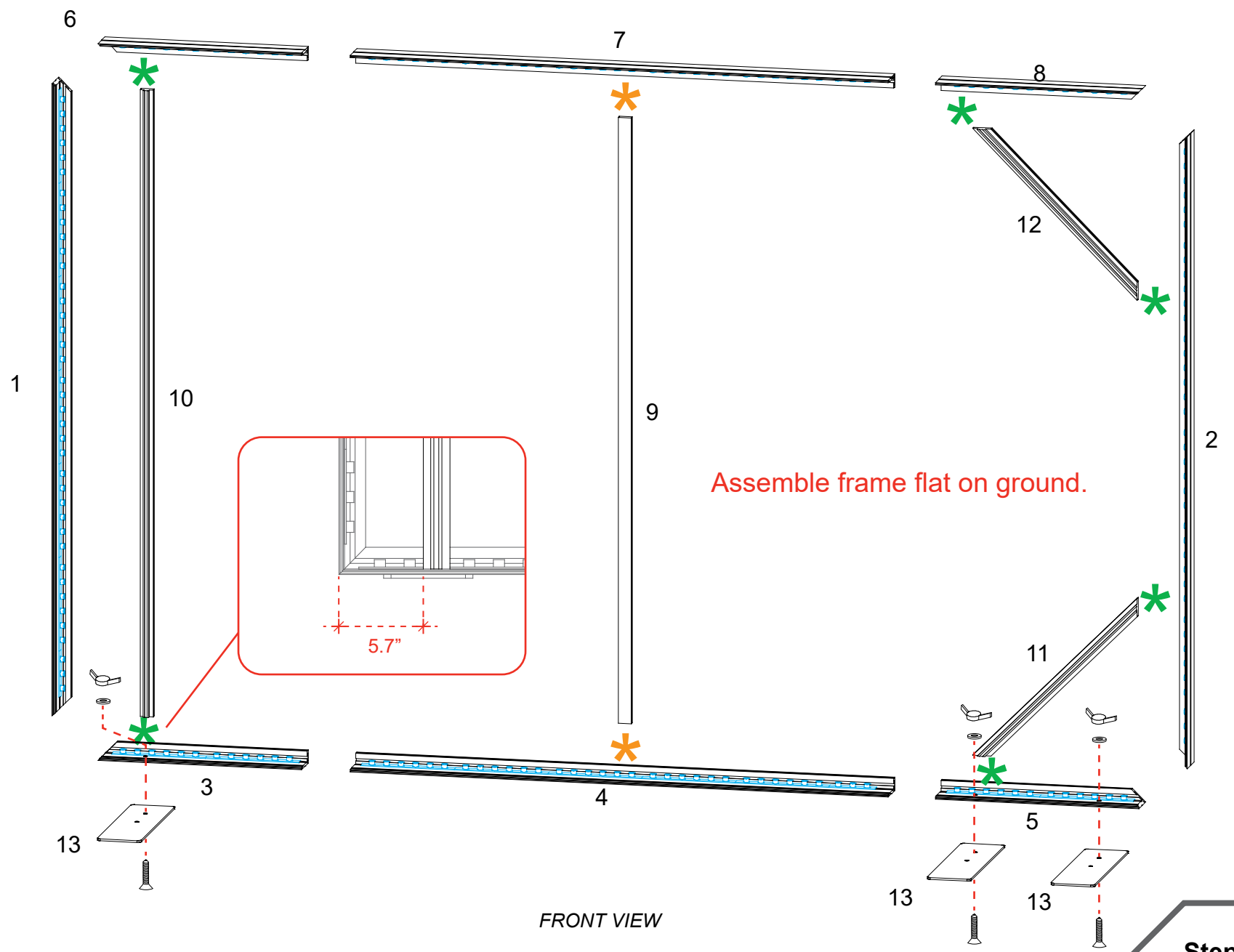
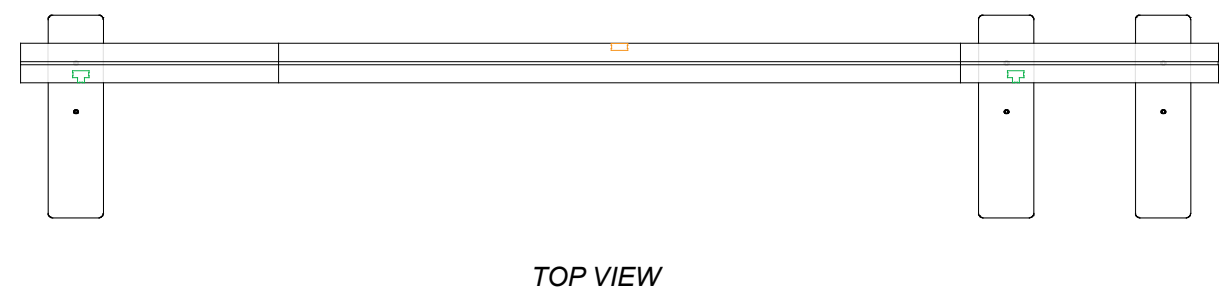
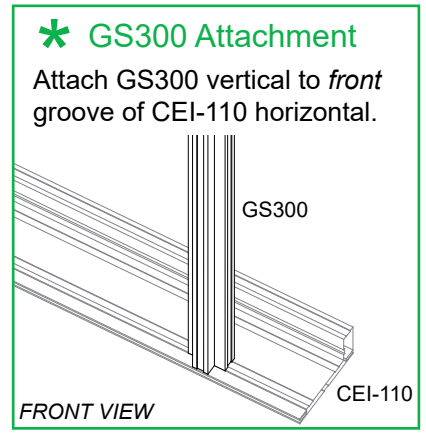

Steps:
1) Connect power cords to Supernova lights, as shown.

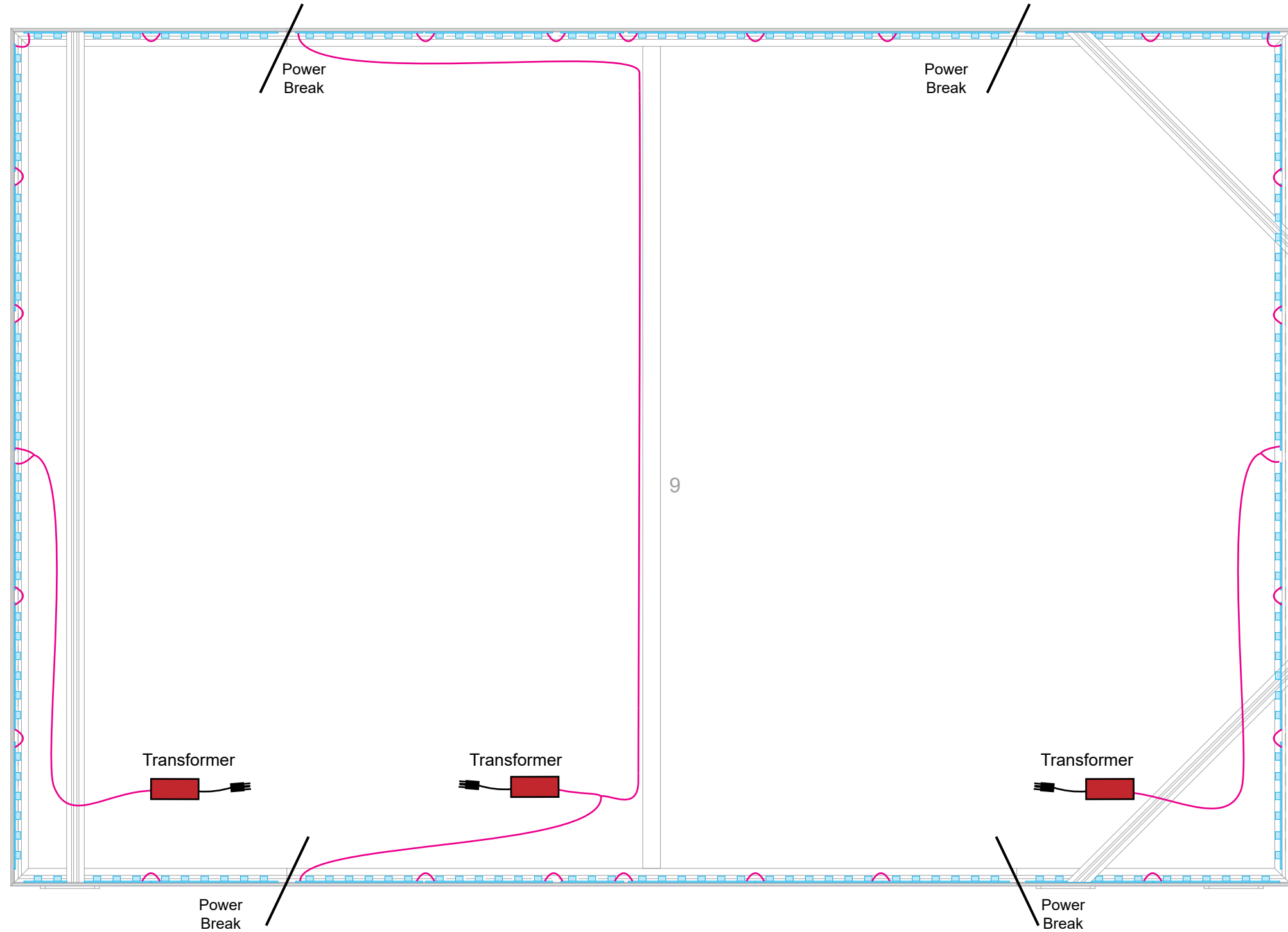
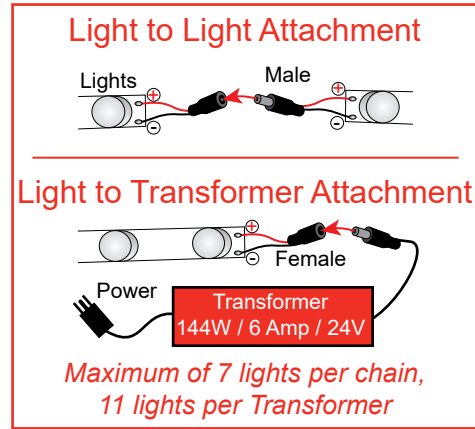

FRONT VIEW

Item	Qty.	Description
1	1	90"h CEI110 Vertical Extrusion
2	1	51.962" CEI110 angled Extrusion
3	1	51.962" CEI110 angled Extrusion
4	1	73.019"w CEI110 Horizontal Extrusion
5	1	73.019"w CEI110 Horizontal Extrusion
6	2	86.353"h Z45 Vertical Extrusion
7	1	86.353"h Z45 Vertical Extrusion
8	1	Corner Base Plate

Steps:

Refer to the CEI-110 Frame Assembly general information page.

- 1) Assemble angled extrusions [2-3] together using custom angle corner connector.
- 2) Attach verticals [1], [2/3] between horizontals [4,5].
- 3) Connect verticals [6,7] between horizontals [4,5].
See **Z45 Attachment** detail.
- 4) Attach Corner Base Plate to extrusions [1,4] as shown.
See **Corner Base Plate Attachment** detail.

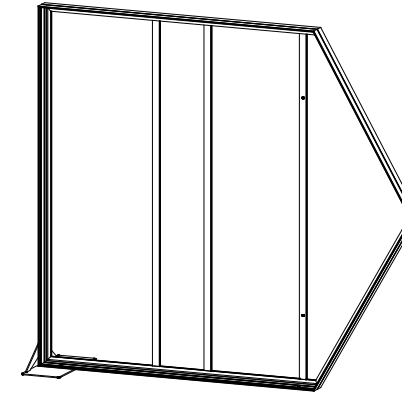

When assembled

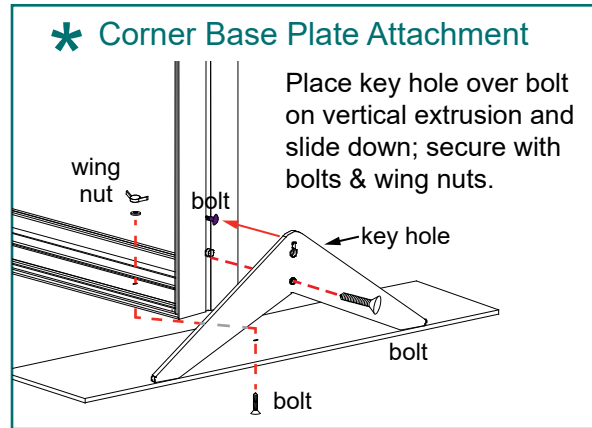
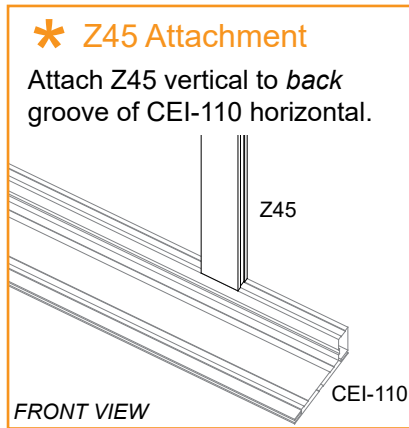

Assemble frame flat on ground.

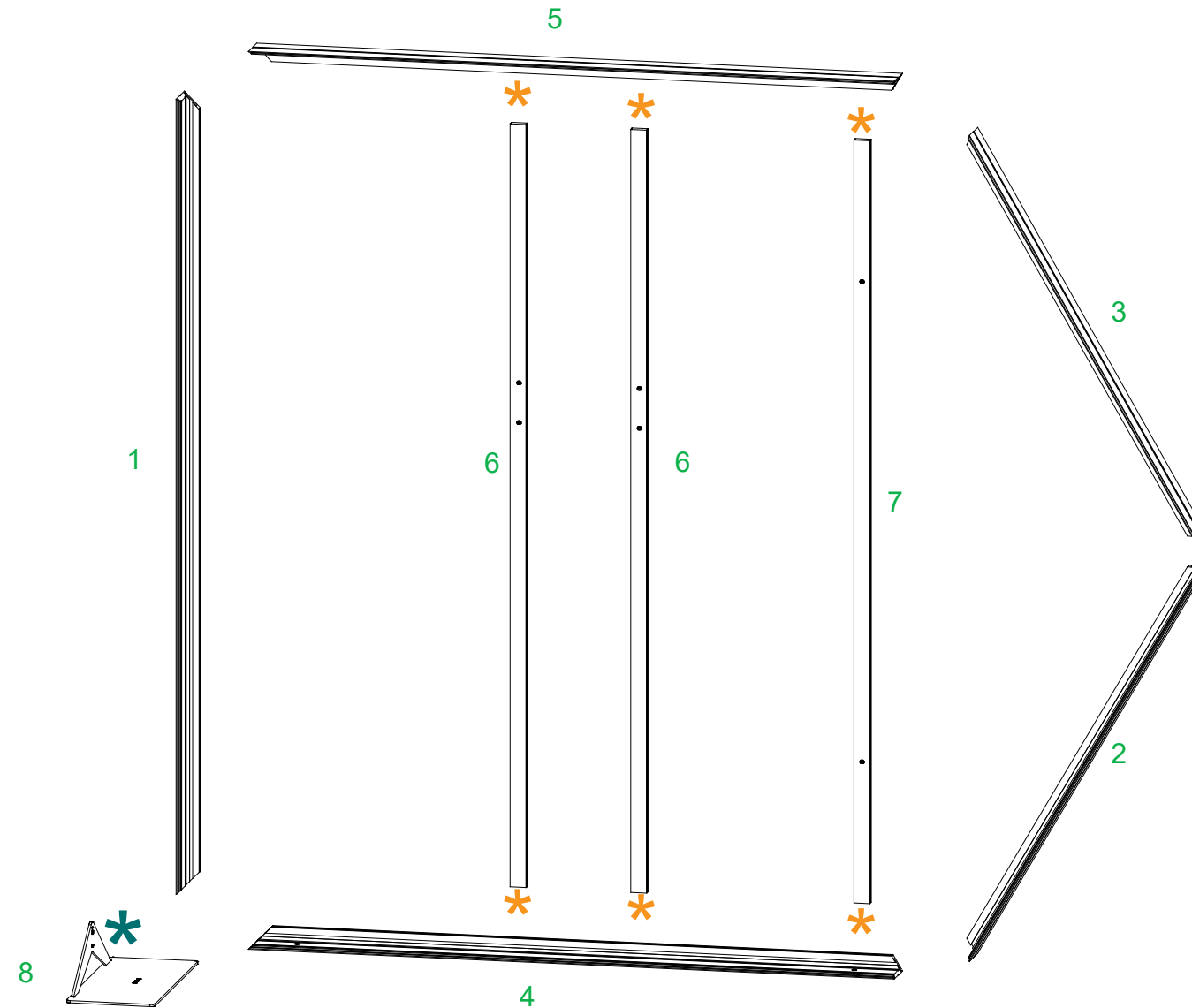

FRONT VIEW

Item	Qty.	Description
1	1	51.962" CEI110 angled Extrusion
2	1	51.962" CEI110 angled Extrusion
3	1	51.962" CEI110 angled Extrusion
4	1	51.962" CEI110 angled Extrusion
5	1	31.019"w CEI110 Horizontal Extrusion
6	2	31.019"w CEI110 Horizontal Extrusion
7	1	23.217" Z45 angled Extrusion
8	1	23.217" Z45 angled Extrusion

Steps:

Refer to the CEI-110 Frame Assembly general information page.

- 1) Assemble angled extrusions [1-2], [3-4] together using custom angle corner connector.
- 2) Attach angled assemblies [1/2], [3/4] between horizontals [5,6].
- 3) Connect extrusions [7,8] between extrusion assemblies [1/2], [3/4].
See [Z45 Attachment](#) detail.

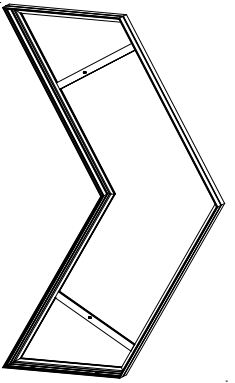

When assembled

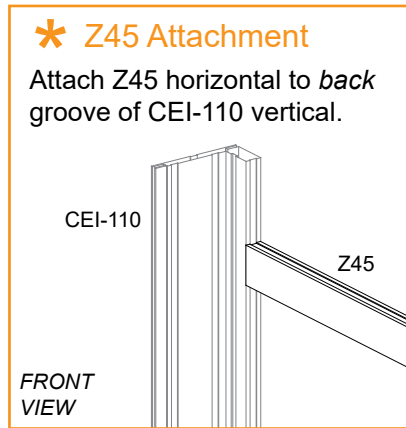

Assemble frame flat on ground.

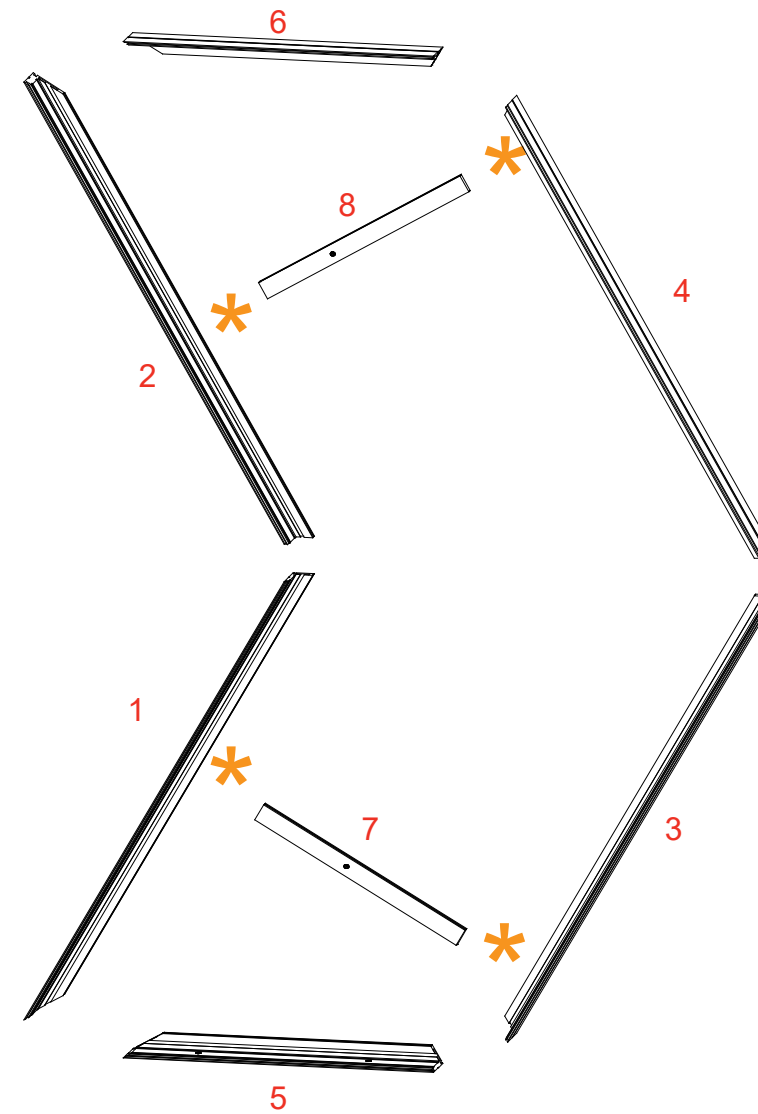

FRONT VIEW

Item	Qty.	Description
--	2	1" Standoff Barrel w/ V20
--	4	3.5" Standoff Barrel

*** Standoff Barrel Attachment**

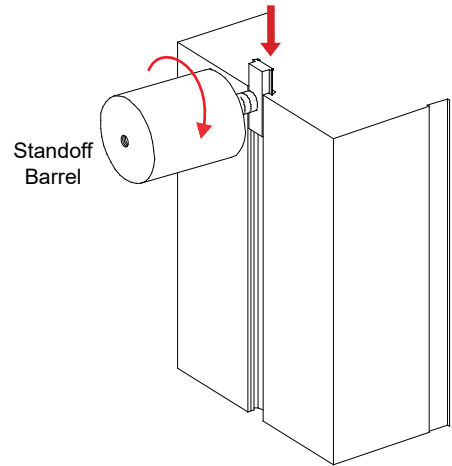

Slide connector on back of standoff barrel into groove of extrusion. Twist to secure in place.

Note: Standoff Barrel attaches through SEG Graphic.

Steps:

Refer to the SEG Installation general information page.

- 1) Apply SEG Graphic to front of Center Lightbox assembly.
- 2) Attach 1" Standoff Barrels to vertical [10] of Center Lightbox assembly. See **Standoff Barrel Attachment** detail.
- 3) Connect Left Frame vertical [7] to Standoff Barrels, using bolts.
- 4) Attach Left Frame horizontal [4] to base plate [13] using bolts & wing nuts.
- 5) Apply SEG Graphic to Left Frame assembly.
- 6) Install Monitor Mount to verticals [6] of Left Frame assembly, using 3.5" Standoff Barrels. See **Monitor Mount Attachment** detail.

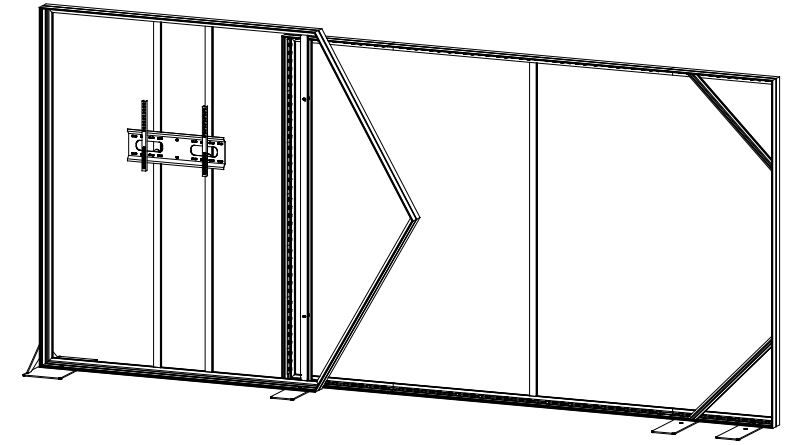

When assembled

*** Monitor Mount Attachment**

Attach Standoff Barrels to verticals using bolts from back side of extrusions. Then attach Monitor Mount to front of Standoff Barrels, using bolts.

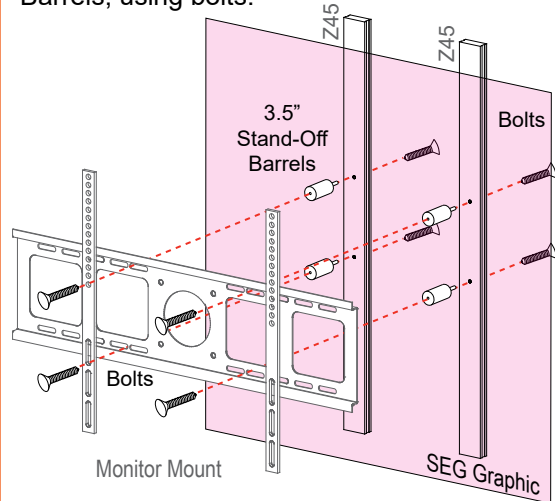

Note: Monitor mount installs over SEG graphic.

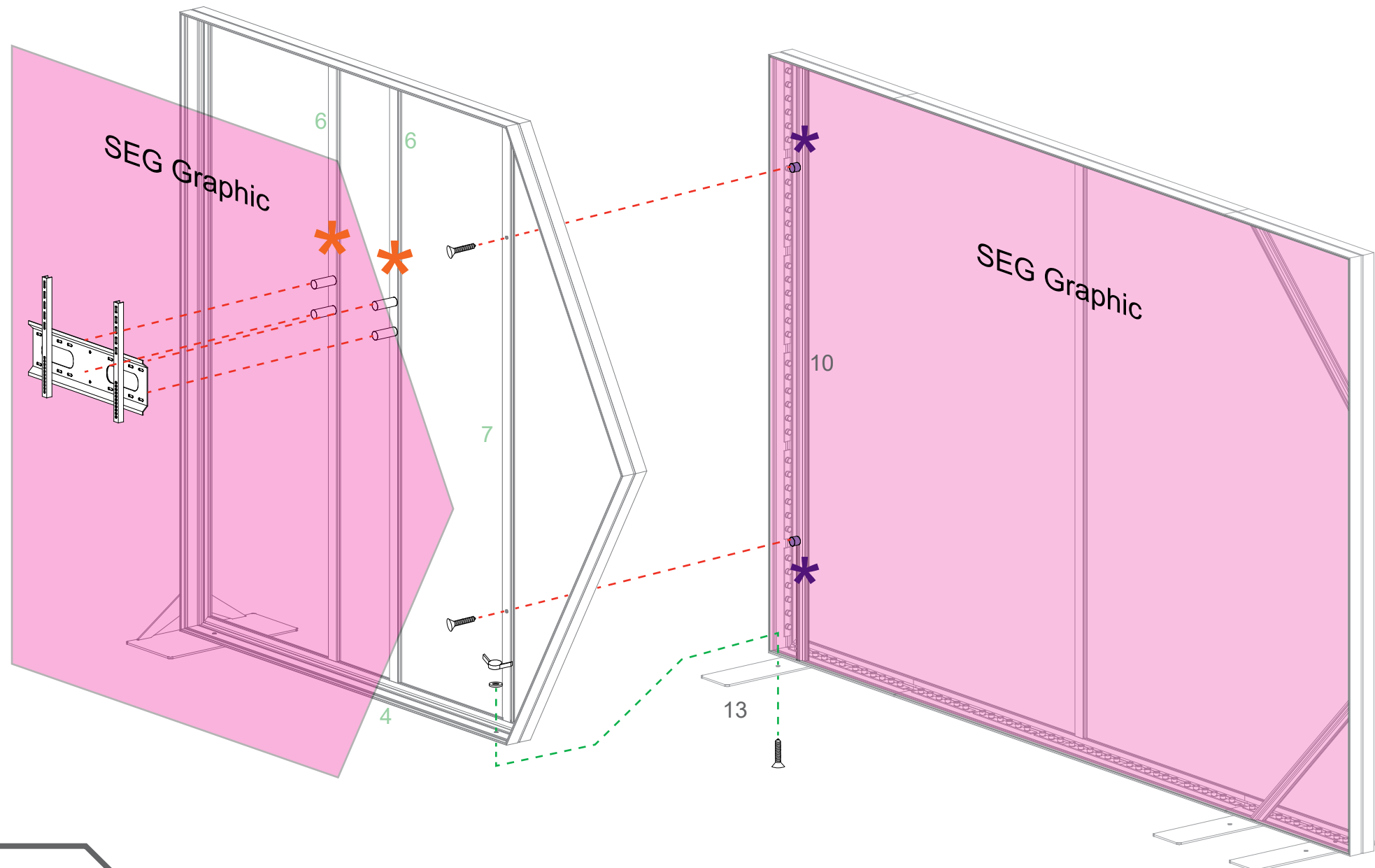

Item	Qty.	Description
--	2	1" Standoff Barrel w/ V20

Steps:

Refer to the SEG Installation general information page.

- 1) Attach 1" Standoff Barrels to extrusions [11,12] of Center Lightbox assembly. See Standoff Barrel Attachment detail.
- 2) Connect Right Frame extrusions [7,8] to Standoff Barrels, using bolts.
- 3) Apply SEG Graphic to Right Frame assembly.
- 4) Apply SEG Blocker to back of Center Lightbox assembly.

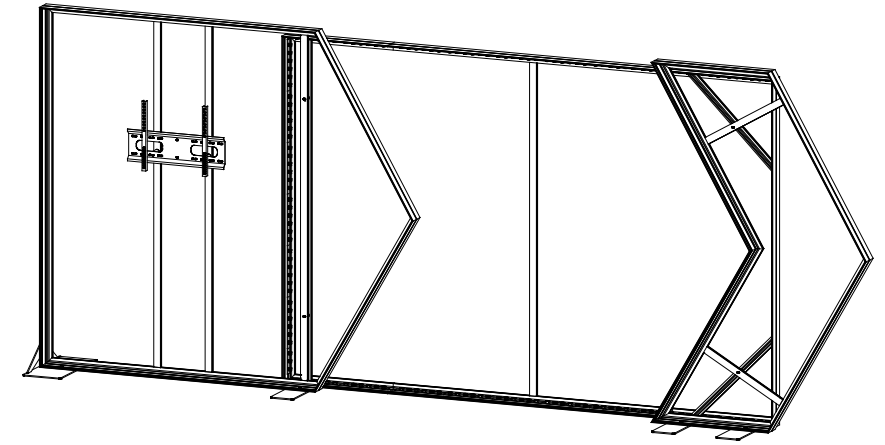

When assembled

*** Standoff Barrel Attachment**

Standoff Barrel

Slide connector on back of standoff barrel into groove of extrusion. Twist to secure in place.

Note: Standoff Barrel attaches through SEG Graphic.

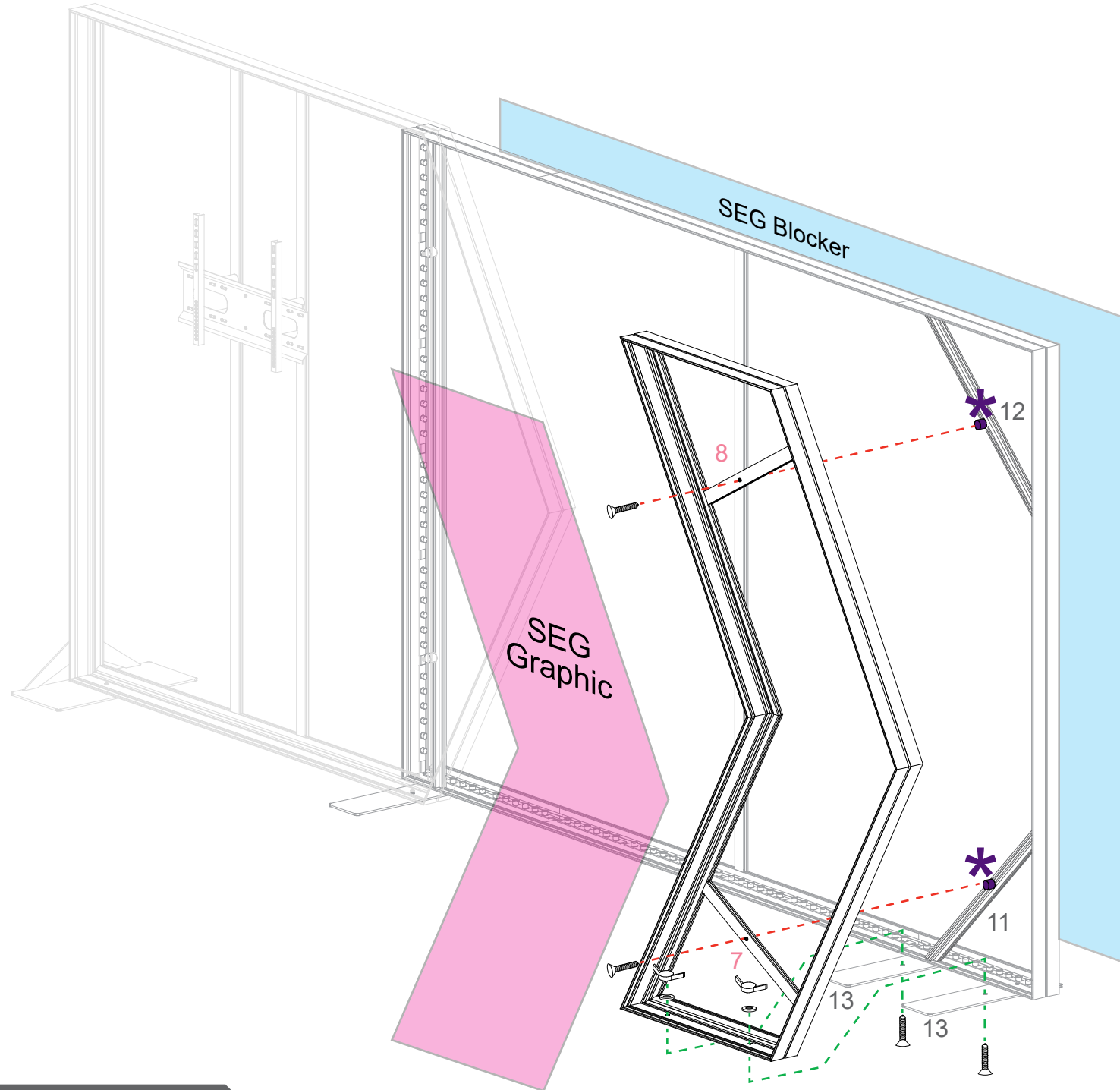

Item	Qty.	Description
--	5	3.5" Standoff Barrel w/ cap

- Steps:
- 1) Connect power cords to Supernova lights inside Counter Unit.
 - 2) Attach power cords to wireless chargers in counter top.
 - 3) Connect graphic to front of Counter, using standoffs & caps.
See **Graphic Attachment** detail.

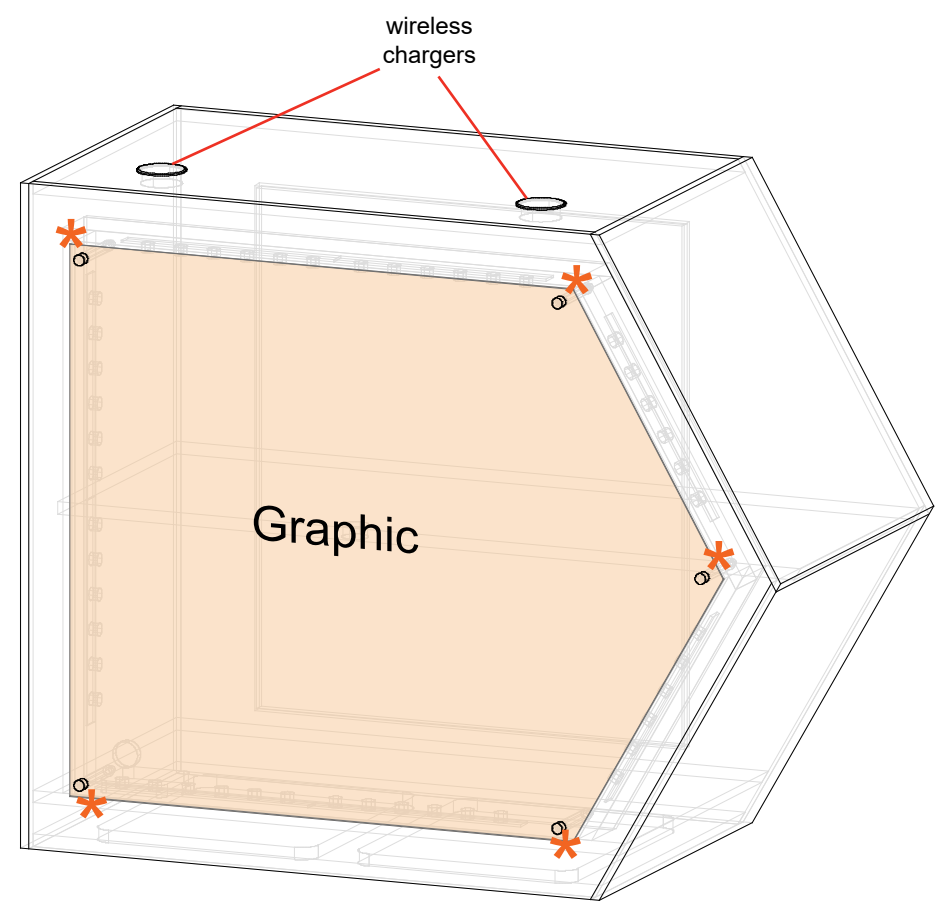
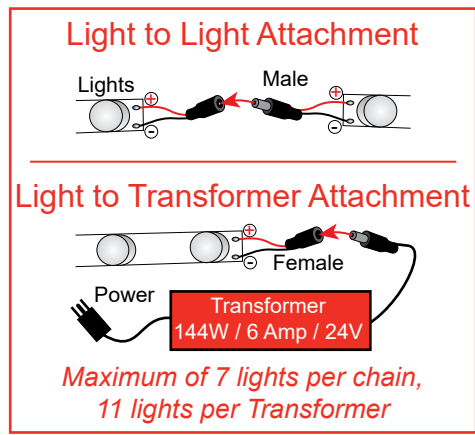

FRONT VIEW

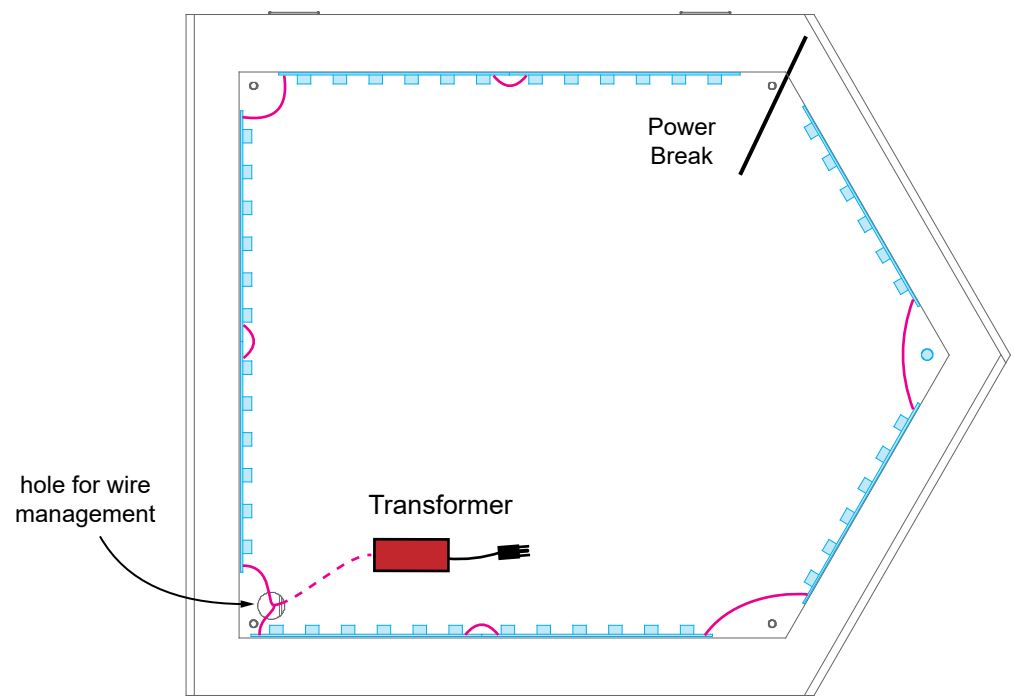

ELEVATION VIEW

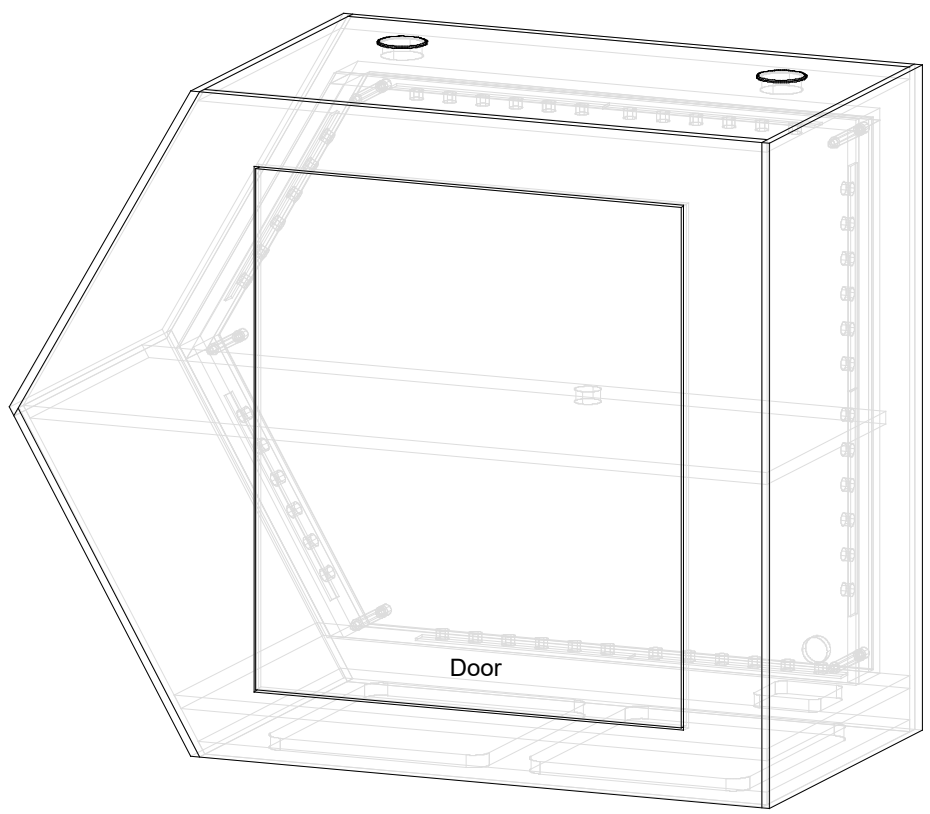
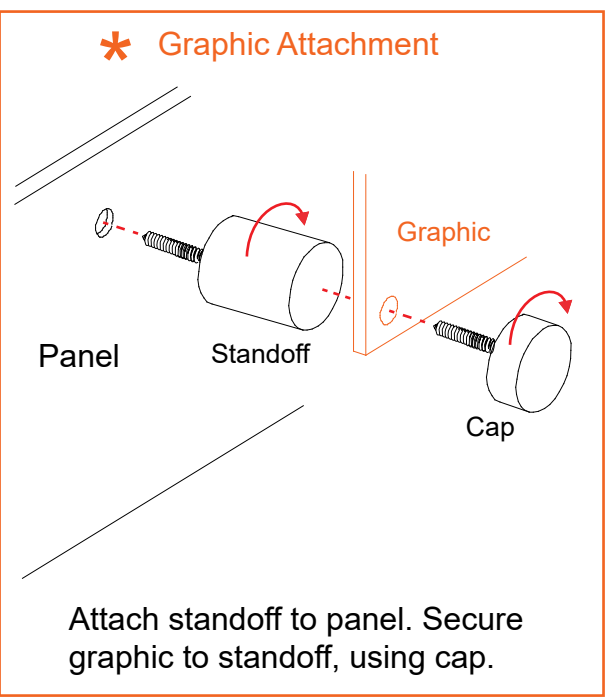

BACK VIEW